

PROFESSIONAL KITCHENS

CABINETS FOR PROFESSIONAL KITCHENS

Model: SFN/01

Code: 45001780

SPACE

POSITIVE UPRIGHT CABINET "SLIM" VERSION -
Refrigerated upright SLIM cabinet. Prearranged for remote
condensing unit with valve system on request.

- Construction: made in stainless steel
- Internal capacity: 445x560 mm racks
- Position of technical compartment: on top
- Refrigeration type: ventilated cooling system
- Control board panel: 2.8" touch control panel, digital display
- Prearranged to be installed on plinth
- Defrosting system: automatic with heating elements
- Evaporation of condensation water: automatic
- Optional equipment: prearranged for remote system (R452A gas valve)
- Supply with: 3 445x560mm shelves





Technical Data:

Doors	nr	1
Capacity (net)	l	289
Capacity (gross)	l	435
External dimensions (WxDxH)	cm	64 x 72 x 209
Insulation thickness	mm	60
Tray pitch	mm	65
Rack positions	nr	19
Evaporators	nr	1
Standard lock		NO
Standard light		NO
Temperature	°C	-2/+8°C
Condensing unit		plug-in unit
Gas		R600a
Ventilation control		NO
Humidity control		NO
Max abs. power	W	260*
Cooling power	W	370*
Input voltage		1x230V ~ 50Hz
Energy efficiency class		B
Energy consumption kWh/24h	kWh/24h	1,01
Energy consumption kWh/year	kWh/year	368
Energy efficiency index		34,1
Climate class		5
Packaging dimensions (WxDxH)	cm	77 x 74 x 224
Volume (gross)	mc	1,28
Net weight	kg	94
Gross weight	kg	104

*Evap. -10°C, Cond +45°C

DETAILS:



Door lock with key



Digital touch thermostat



65mm pitch, 19 positions



Ventilated cooling system



Ecological gas (R290)



Remote monitoring system via GEMM-Cloud Wi-Fi connection (on request)

ACCESSORIES:



44,5x56 shelf

45001740



Pair of runners for 44,5x56 cm shelf

45001745



Pedal for single door

45000530



Set of Ø 100 castors

45000540



Wi-Fi supervising system (overprice)

45000565



60Hz frequency

40200560



Prearranged version with valve system for normal temperature equipment (deduction)

INSTALLATION DIAGRAM:

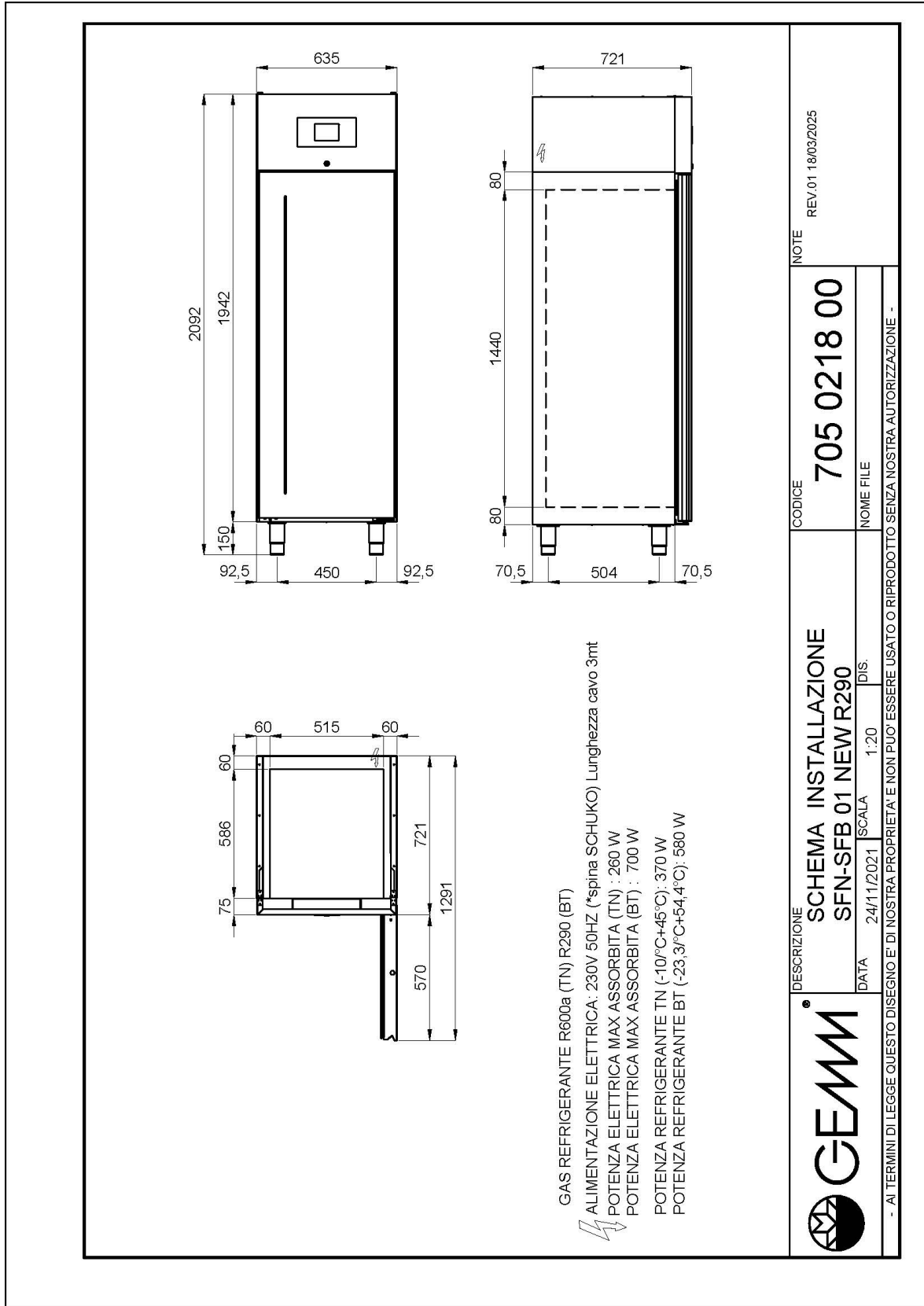

SFN/01

ECOLABEL:

